

PRODUCT DETAILS

PRODUCT CODE	NS40ZL	
WARRANTY	30 months (Private Passenger Use) *	
CHARACTERISTIC	Sealed Maintenance Free Lead Acid Battery	
GROUP SIZE	NS40	
CASE AND LID	Material : Polypropylene (PP)	
	Handle : 1 pc Plastic	
	Ledges : No Ledge (NL)	
	Venting System : Centralized system with Degassing vents on sides	

DIMENSIONS, WEIGHT, AND LAYOUT

OVERALL DIMENSIONS	METRIC
LENGTH, mm	196
WIDTH, mm	128
CASE HEIGHT, mm	199
TOTAL HEIGHT, mm	219
APPROXIMATE WEIGHT, kg	9.72

TERMINAL DATA	METRIC
TYPE	JIS
TERMINAL HEIGHT, mm	18.5±1.5
BOTTOM DIAMETER, mm	Positive: 14.7+0/-0.3 Negative: 13.0+0/-0.3
TAPER	1:9
POLARITY	C (Positive Right)

CAPACITY SPECIFICATIONS

COLD CRANKING AMPS (CCA)	340 CCA
AMPERE-HOUR AT 20-HOUR CAPACITY	38 Ah
RESERVE CAPACITY (RC)	55 mins

MAX CHARGING VOLTAGE	14.8 V at 25°C
FLOAT CHARGING VOLTAGE	13.5 V – 13.8 V at 25°C
OPERATING TEMPERATURE	-40°C to 80°C** Optimal Temperature: 25°C ± 5°C

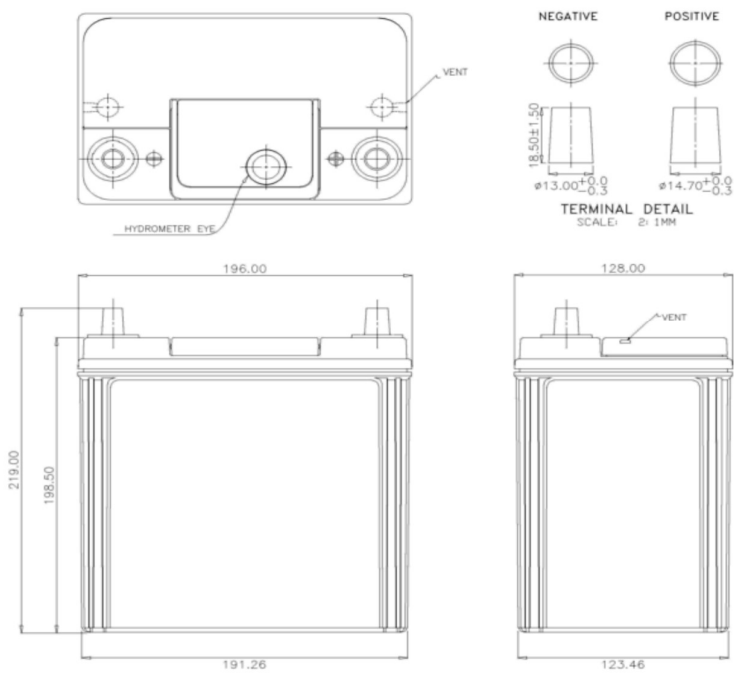

*Warranty terms and conditions apply.

**Based on normal engine bay temperature.

(Note) The company reserves the right to update the information above without prior notice.